

**ART. 403-TF** Contatto magnetico in termoplastico con cavo 0,3 m / Thermoplastic magnetic contact with cable 0,3 m

**ART. 403-TF-4** Contatto magnetico in termoplastico con cavo 4 m / Thermoplastic magnetic contact with cable 4 m

**SPECIFICHE GENERALI  
GENERAL SPECIFICATIONS**

<b>Materiale contenitore Housing material</b>	Termoplastico colore bianco White color thermoplastic
<b>Funzionamento Operation</b>	NC con i due componenti vicini NC when the two components are near
<b>Temp. di funzionamento Operating temperature</b>	-25°C ÷ +50°C
<b>Grado di protezione IP degree</b>	Certificato IPx2 (dichiarato IP65 da Cooper CSA) Certified IPx2 (declared IP65 by Cooper CSA)
<b>V max</b>	42,4 Vpeak - 60Vdc
<b>I max</b>	1 A
<b>W max</b>	10 W
<b>Identificazione Identification</b>	Numero seriale/lotto su ogni componente Serial number/batch on each component

I contatti magnetici sono componenti passivi, le grandezze elettriche indicate sono le massime applicabili  
Magnetic contacts are passive components, max applicable voltage and current are displayed in table



**INSTALLAZIONE CONFORME ALLA NORMA  
INSTALLATION AS PER STANDARD**

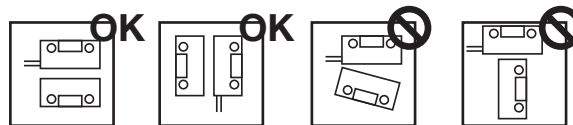
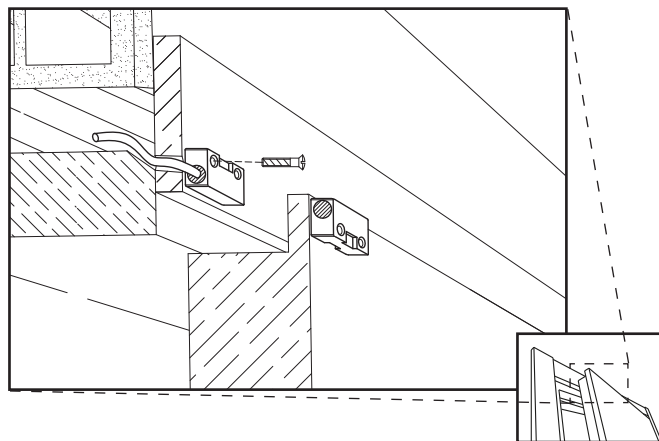









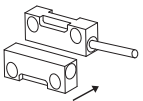
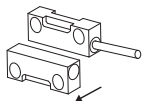
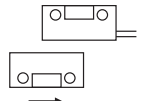
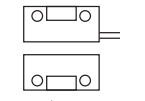
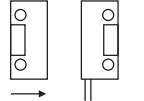
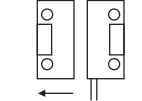



La certificazione decade per installazioni diverse da quelle rappresentate nelle figure.  
Certification is void if the devices are installed differently.

## DISTANZE OPERATIVE / OPERATIONAL APPROACH AND REMOVAL DISTANCES

Installare i due corpi a distanza Y inferiore a 15mm (distanza raccomandata 10mm). Le distanze operative riportate in tabella per gli assi X e Z sono state calcolate con i corpi installati alla distanza raccomandata. Non installare su superfici ferromagnetiche.

Install the two components at Y distance less than 15mm (recommended 10mm). The operating distances displayed in table for axes X and Z have been calculated with the components mounted at the recommended distance. Do not install on ferromagnetic surfaces.

Asse / Axis	Z+ / Z-		X+ / X-		Y	
<b>Azione Action</b>						
<b>Contatto Contact</b>						
<b>Superfici non ferromagnetiche Non-ferromagnetic surfaces</b>	16 mm	26 mm	7 mm	15 mm	15 mm	22 mm
<b>Superfici ferromagnetiche Ferromagnetic surfaces</b>						
Tolleranze / Tolerance	-0% +30%	+0% -30%	-0% +50%	+0% -50%	-0% +30%	+0% -30%

## INDICAZIONI DI FISSAGGIO / FIXING INSTRUCTIONS

Fissare i componenti tenendo conto delle distanze operative riportate in tabella. Utilizzare viti autofilettanti  $\varnothing 2,2$ . Installare i due componenti rispettando l'allineamento dei fori indicato nella figura a lato. Non applicare su superfici ferromagnetiche.

Fix the elements paying attention to the operational approach and removal distance. Use  $\varnothing 2.2$  tapping screws. Install the components according to the alignment of the holes depicted in the picture aside. Do not install on ferromagnetic surfaces.

## COLLEGAMENTO / WIRING

